

ONE COMPARTMENT SINKS W/ TWO DRAINBOARDS & THREE SIDED CROSS BRACING



PROJECT#: _____

ITEM# _____

MODEL# _____

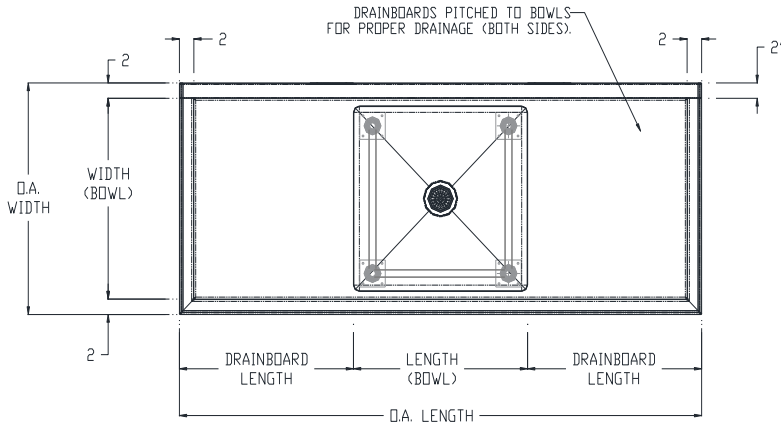

PLAN

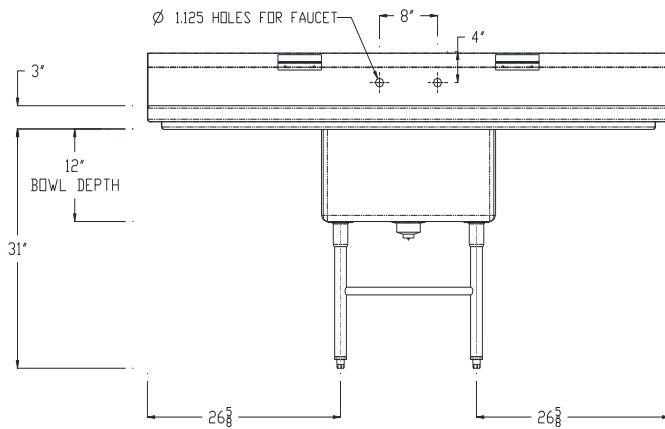
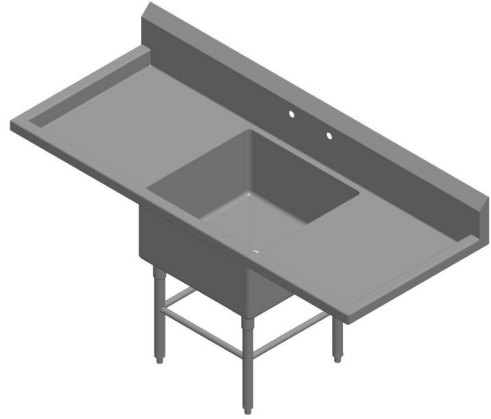

ELEVATION

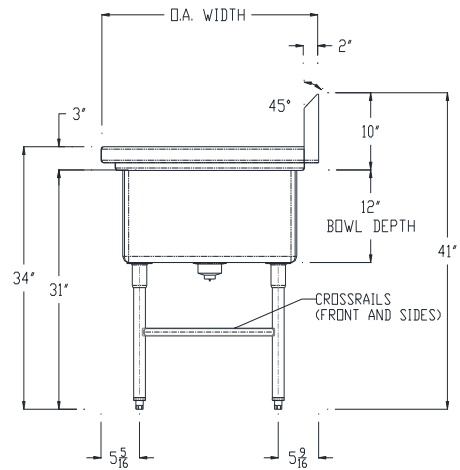

SECTION A-A

ONE COMPARTMENT SINKS W/ TWO DRAINBOARDS & THREE SIDED CROSS BRACING								
MODEL#	QTY	PRODUCT DIMENSIONS (INCHES)						SHIPPING WEIGHT (LBS)
		LENGTH (BOWL)	WIDTH (BOWL)	DRAINBOARD LENGTH	O.A. LENGTH	O.A. WIDTH	OVERALL HEIGHT	
C-1-1618-18D-CC		16"	18"	18"	52	24"	41"	93
C-1-1618-24D-CC		16"	18"	24"	64	24"	41"	101
C-1-1818-18D-CC		18"	18"	18"	54	24"	41"	95
C-1-1824-18D-CC		18"	24"	18"	54	30"	41"	103
C-1-1824-24D-CC		18"	24"	24"	66	30"	41"	109
C-1-2424-18D-CC		24"	24"	18"	60	30"	41"	115
C-1-2424-24D-CC		24"	24"	24"	72	30"	41"	127
C-1-3024-24D-CC		30"	24"	24"	78	30"	41"	145

SINK SPECIFICATIONS:

TOP: 16 GA. 300 Series Stainless Steel

SINK BOWLS: 16 GA. 300 Series Stainless Steel

CROSS BRACING: 1" Diameter Stainless Steel Welded to Legs

LEGS: 1 5/8" Diameter Stainless Steel Tubing

CONSTRUCTION:

- ◆ Fully welded, Seamless, Polished to #4 Finish
- ◆ Euro Edge
- ◆ S/S Adjustable Bullet Feet
- ◆ Crumb Cup Drain 1 1/2" IPS
- ◆ 8" On Center Faucet Holes
- ◆ Ships with (2) Wall Mount "Z" Clips
- ◆ Integral 10" Tall Backsplash